

Standard Grease Bin



SAFE, SECURE HANDLING

These standard grease bins are safe and secure for handling restaurant grease collection, used motor oil collection as well as many other uses.

- 14 GA steel construction. No plastic fire hazard
- Hinged steel lid for secure containment and easy access
- Lockable grate for safety and theft prevention
- Lock housing cover for added security
- Full inseam weld (watertight)
- Every unit is hydro static tested for leaks
- Exterior (including bottom) painted with primer and your choice of standard color with alkyd enamel paint. Some colors may be extra. Stock color is black
- 2 - 7 GA steel skids at bottom for stability
- Standard one year parts and labor warranty
- Available in 89, 134, 209 & 314 gallon

Available Options include:

- 1/4" steel caster reinforcement plates (not available on 89 gallon size)
- Sturdy 3X2 Phenolic Casters, 2 rigid, 2 swivel with QRCP (not available on 89 gallon size)
- Choice of perforated grate or bar grate model
- Choice of 1" or 2" spacing on bar grate model
- Heat tubes for warming product in cold climates
- Lockable hasp on lid for additional security
- ID weld for positive identification of each unit

Standard Grease Bin



Dimensions and Drawing

Product #	Size Gallons	Height * (A)	Width (B)	Length (C)
715	89	36"	24"	24"
716	134	36"	24"	36"
717	209	36"	28"	48"
718	314	36"	42"	48"

* Skids add 1-1/2" to height.

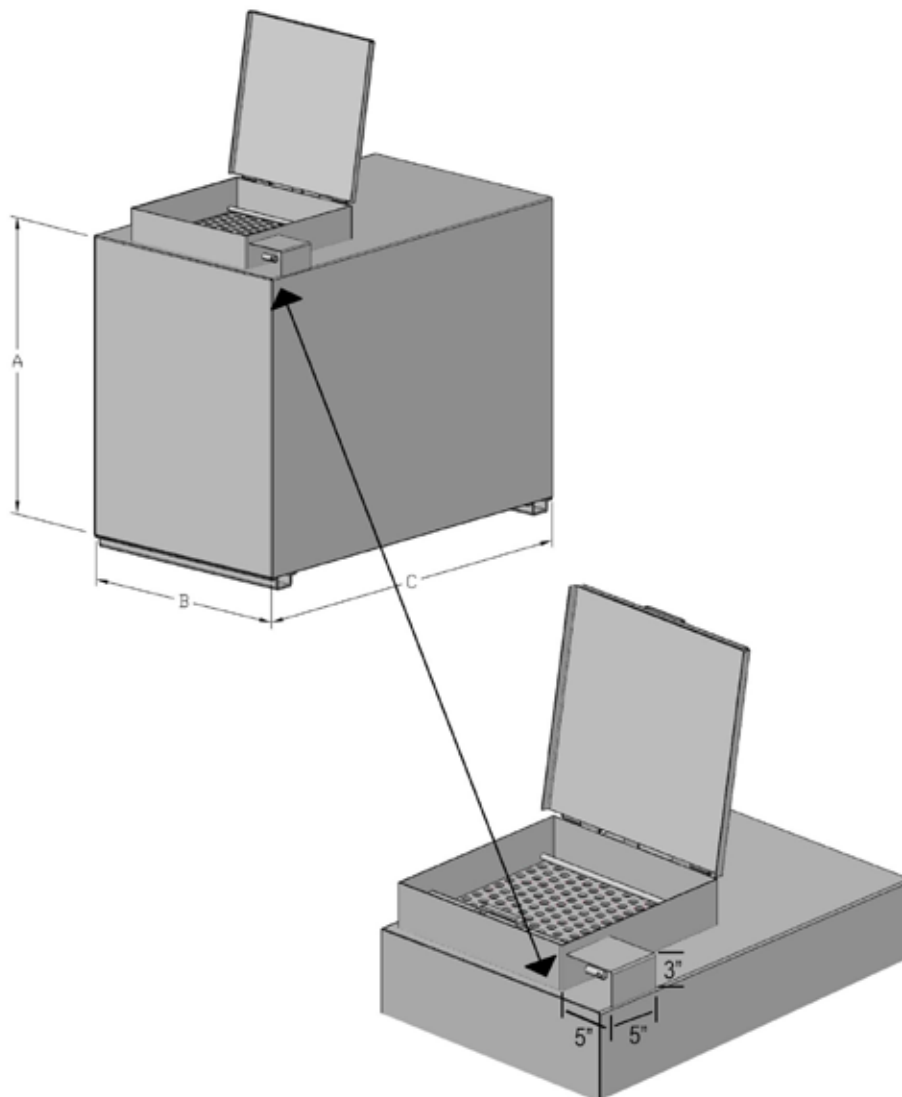

Dimensions for Perforated & Bar Grates on following pages. Both grate styles are interchangeable on all sizes of Standard Grease Bins.

Standard Grease Bin



Standard Perforated Grate

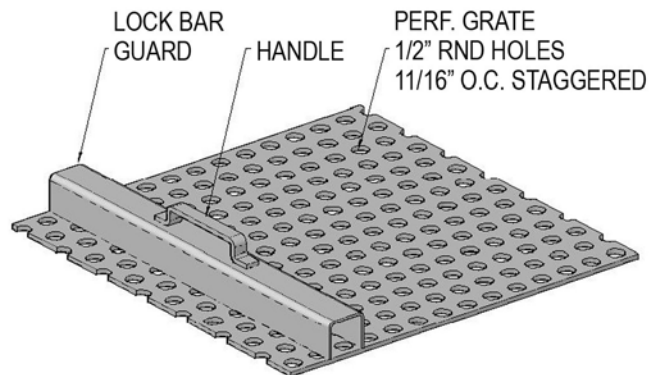
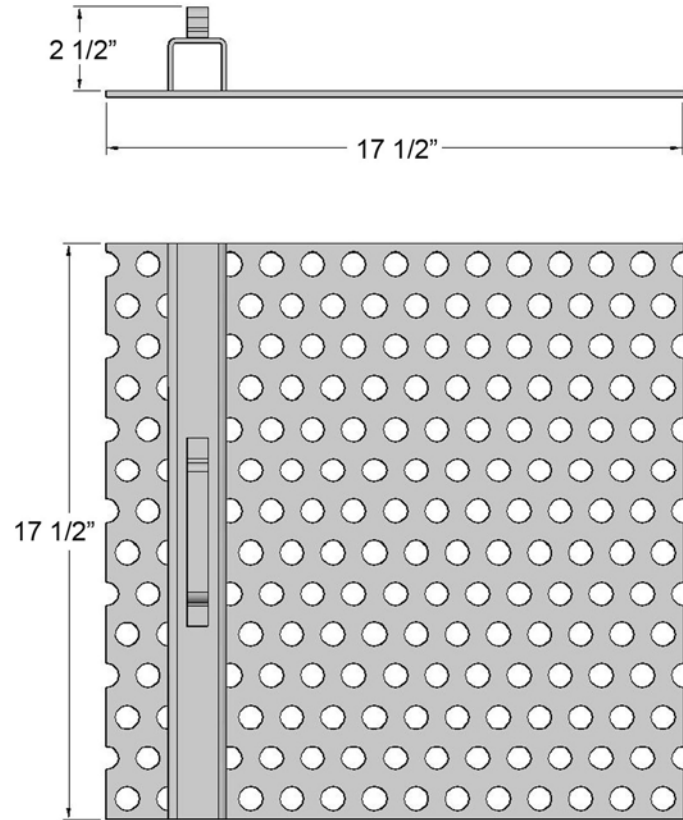

Standard Grease Bin



Standard Bar Grate

