

### QUALITY, DURABILITY, VALUE

#### Standard Specifications

##### Ground Vaults

- Plastic lids.
- 10 GA construction.
- Coated with rust inhibitive alkyd primer.
- Exterior top portion painted your choice of standard color with alkyd enamel paint. Some colors may be extra.
- Buried in the ground to have a lower loading height for the container.
- Helps prevent theft.

##### Ground Vault Containers

- End loader channels.
- 14 GA construction with flanged corners and horizontal "V" groove ribs front, back and bottom.
- 10 GA full length fork channels.
- Full inseam weld in and out.
- Interior coated with rust inhibitive alkyd primer.
- Exterior (including bottom) painted your choice of standard color with alkyd enamel paint. Some colors may be extra.

REV	DATE	DESCRIPTION	INT

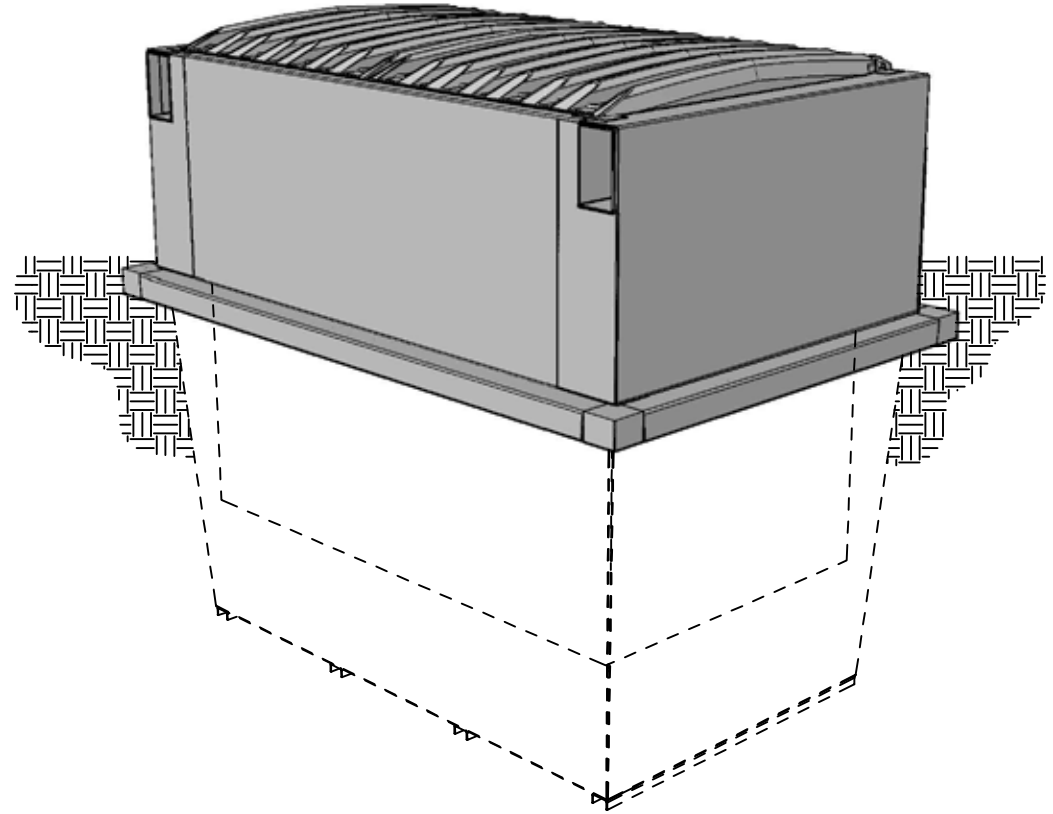
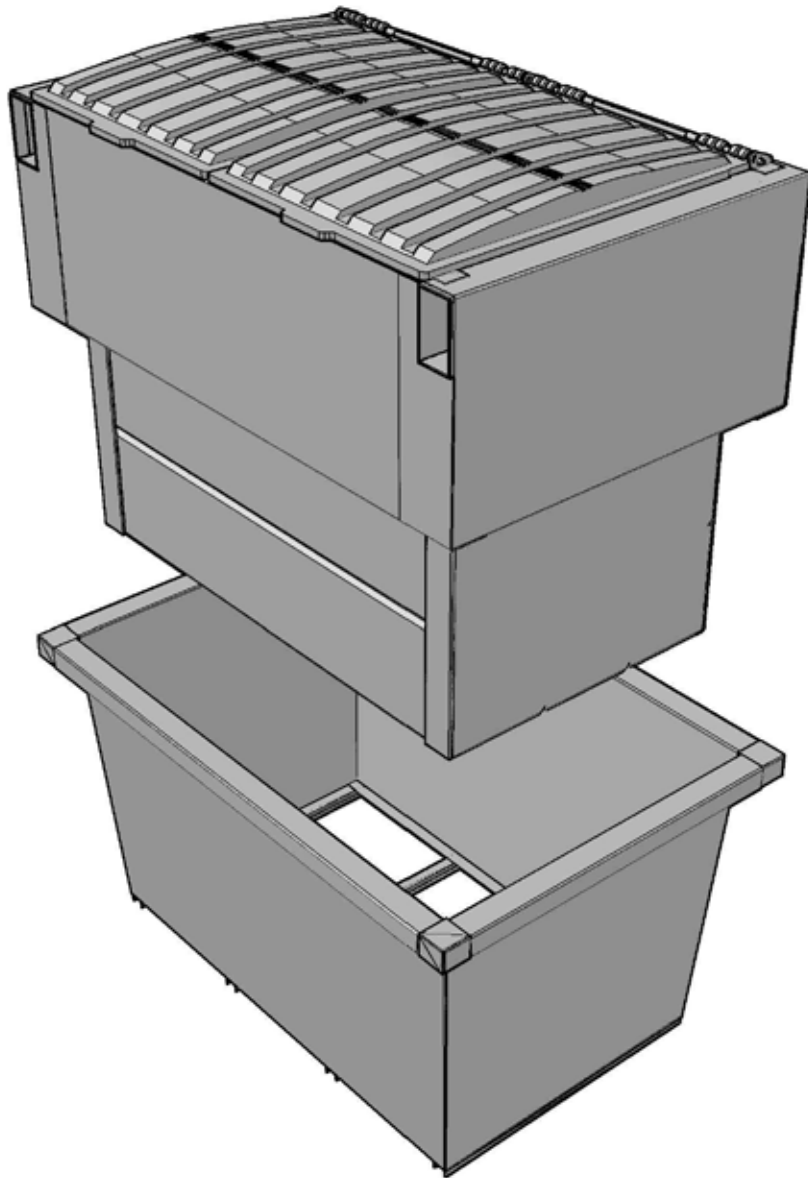

NOTES:  
 1) ALL DIMENSIONS ARE IN INCHES, +/- 1/4", UNLESS OTHERWISE SPECIFIED ON THE DRAWING.  
 2) PLEASE REVIEW DRAWING(S), MAKE ANY CHANGES OR MODIFICATIONS THAT ARE APPROPRIATE, SIGN AND RETURN.

CUSTOMER SIGNATURE REQUIRED TO PROCEED



**CONFIDENTIAL PROPERTY OF CFC**

THIS DRAWING AND ALL OF THE INFORMATION CONTAINED HEREIN IS THE SOLE PROPERTY OF CONSOLIDATED FABRICATORS CORP. AND IS ONLY TO BE VIEWED, COPIED, SHARED OR TRANSMITTED BY AUTHORIZED PARTIES.



TITLE: VAULT & VAULT CONTAINER			
DRAWN BY: F. DUTRA	DATE: 05-15-13	SCALE: N.T.S.	CUSTOMER: PROSPECTIVE CUSTOMER
(800)635-8335 TOLL FREE		www.con-fab.com	PAGE: 1 OF 1
			FILE NAME: ENG\CUSTOMER\FILE NAME